

Specification sheet

XB 120

FA 4X2 Rigid, 12t Electric ChsBody

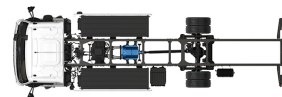

ENGINES

XB BEVNewGen rnal (mbusti / No hp listing)

GVM¹⁾

12000 kg

Max. front 4480 kg

Max. rear 8480 kg

GCM²⁾

12000 kg

CAB EXTERIOR

Day Cab with steel bumper, tinted glass and electric window openers. Main mirrors and wide angle mirrors electrically heated. Cab width 2130 mm.; Electrically adjustable mirrors; Mirror brackets, body 2.50-2.60 m; Front view mirror; Rear view camera.

Optional

02576 Extended Day Cab	02083 Two hazard beacon lights LED
03175 Cab suspension rubber and mechanical	07343 Kerb view window co-driver door
01605 Cab suspension mechanical reinforced	00915 Side no glass / rear single glass
09983 Fog lights	09101 Green tinted glass, heated
09984 Fog lights and cornering lights	09283 Mirror brackets, body 2.40-2.50 m
06629 Two hazard beacon lights	

AERODYNAMICS

Optional

09286 Roof air deflector prepared	07092 Adjustable roof air deflector low (set)
06776 Adjustable roof air deflector	09287 Side collars prepared
07109 Adjustable roof air deflector high (set)	07112 Side collars long (set)

COLOURS

; Head lamp panel and bumper: Stone Grey; Cab steps and wing Stone Grey; Chassis colour grey..

Optional

06485 Head lamp panel and bumper: cab colour	01303 Curtain colour 557 blue, panels white
01109 Cab steps and wing in cab colour	01340 Curtain colour 602 green, panels white
04674 Body panels standard white	01344 Curtain colour 763 grey, panels white
01238 Curtain colour 907 white, panels white	01350 Curtain colour 905 black, panels white
01241 Curtain colour 148 yellow, panels white	16153 Cab and chassis colours
01298 Curtain colour 356 red, panels white	

CAB INTERIOR

Right-hand drive (RHD); Mechanically adjustable steering column; Driver seat: air suspended; Co-driver seat: fixed velour; Storage box on engine tunnel.

Optional

01846 Left-hand drive (LHD)	16158 Seat types
09271 Steering wheel, leather, colour black	04246 Roof hatch, manual control
03516 Pneumatically adjustable steering column	04258 Roof hatch, electric control
00967 Seat belts red	

COMMUNICATION AND DRIVING MANAGEMENT

FMS connector, prepared; Tachograph digital, Stoneridge 1C version G2V2; Driver Performance Assistant.

Optional

16155 Audio equipment, makes and types

SAFETY AND SECURITY

Speed limit recognition; DAF drowsiness detection; Drive-off Assist.

Optional

08631 Air bag (driver) and 2 seat belt tensioners	01723 No reverse warning
07414 Reverse warning with self-adjusting volume	

SUSPENSION AND AXLES

Front axle type F48. Parabolic leaf suspension with shock absorbers and stabiliser. Max. load 4.5 tonnes.; Single reduction driven rear axle type SR8.22 with parabolic leaf suspension, including shock absorbers and stabiliser. Max. load 8.5 tonnes..

Optional

01636 Rear: 8.50 t, air suspension, SR8.22	01372 Rear springs air suspension, SR8.22
---	--

WHEELS AND TYRES

Front axle(s): 245/70R17.5; Driven rear axle(s): 245/70R17.5; Goodyear; Wheel protection rings silvergrey.

Optional

06764 Wheel protection rings black	16152 Tyre makes and types black
---	---

DRIVELINE

Electric motor type EX-M1; 120 kW; Battery Electric Vehicle; Rear axle ratio 5.13.

Optional

02843 Mechanical differential lock

BRAKE SYSTEM

Optional

09524 Park brake control with spoken warning

CHASSIS

Wheelbase 4.65 m / rear overhang 2.75 m; Side member height 210 mm; Battery box LH rear, no spare wheel carrier; Battery pack H-type; 1 HV battery pack: L1, H-type; 1 HV battery pack; Spray suppression.

Optional

04181 Battery pack C-type	01696 2 HV battery packs
00703 1 HV battery pack: R1, H-type	01623 Rear underrun protection
00684 2 HV battery packs: L1+ R1, C-type	03323 Rear light with LEDs
00686 2 HV battery packs: L1+ R1, H-type	

DRAWBAR AND TRAILER EQUIPMENT

Closing member.

BODIES AND PREPARATIONS FOR BODYING

Standard body attachment hole pattern.

Optional

09952	BodyBuilder Module (BBM) full	02717	Aluminium kick strips, front and sides 228 mm
00126	Body attachment BAM 1, consoles type B	02712	Aluminium kick strips, front 228 mm
02357	Box body	02727	Galvanised kick strips, front and sides 200 mm
01890	Curtain sider body	02728	Plywood kick strips, front and sides 300 mm
03562	Aerobody	02738	Plywood kick strips, front 1200 mm, sides 300 mm
02622	External body length 6100 mm	04650	Rear wide lath shutter door
02650	External body length 6810 mm	04662	Rear double doors
06463	External body length 7100 mm	02726	Single, hinged side door at front left-hand side
04619	External body width 2480 mm	04297	Single, hinged side door at rear right-hand side
04621	External body width 2540 mm	02718	Side roller shutter door
01403	GRP faced plywood panels	04637	Column tail lift
00067	Contour markings	04640	Tuck-under tail lift
02702	Standard body floor	06464	Tail lift 1.5 tonnes
02698	Body floor with 3 mm aluminium tread plate		

24V POWER SUPPLY

Batteries 2x 125 Ah..

Optional

01257	Batteries 2x140Ah	08797	Batteries 2x175Ah
-------	-------------------	-------	-------------------

GVM AND GCM

Chassis weight related technical GVM max 12000 kg; Driveline related technical GCM equal to GVM.

APPLICATION CONDITIONS

Optional

01282	Moderate climate
-------	------------------

VEHICLE DELIVERY

Standard toolkit.

Optional

06491	Toolkit Eastern Europe
-------	------------------------

XB 120

FA 4X2 Rigid, 12t Electric ChsBody

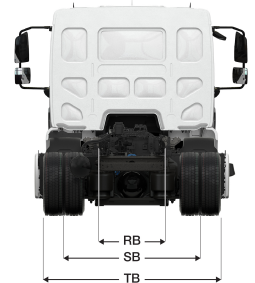
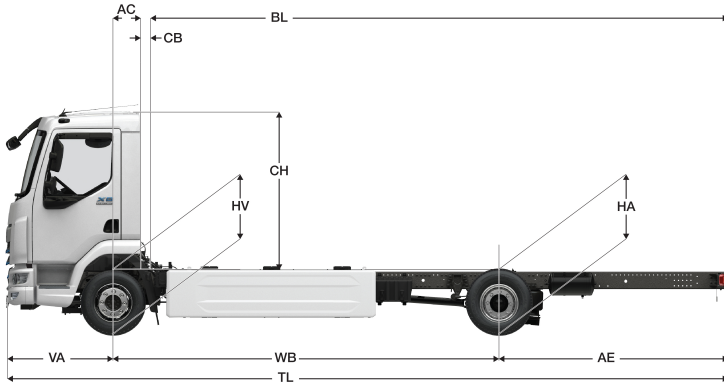

	Wheelbase - AE		Unladen weight ⁹⁾			Gross Carrying Capacity			Variable dimensions									
	WB	AE ⁹⁾	Front	Rear	Total	Front	Rear	Total	AC	CB ⁶⁾	CH ⁷⁾	BL ⁸⁾	BL	TL	HA ⁹⁾	HA ¹⁰⁾	TK ¹¹⁾	TW ¹²⁾
DAY CAB	4,30	2,43	2899	1563	4462	1581	6917	7538	0,32	0,23	1,87	5,68	6,70	8,02	0,85	0,82	13,89	15,01
	4,65	2,75	2958	1478	4435	1522	7002	7565	0,32	0,23	1,87	6,31	7,41	8,69	0,97	0,87	14,75	15,88
	5,00	2,46	2997	1443	4440	1483	7037	7560	0,32	0,23	1,87	6,92	8,10	8,75	0,98	0,89	15,61	16,76

OTHER DIMENSIONS	VA: 1,29	HV ¹³⁾ : 0,90	HV ¹⁴⁾ : 0,88	RB: 0,86	SB: 1,74	TB ¹⁵⁾ : 2,32
------------------	----------	--------------------------	--------------------------	----------	----------	--------------------------

1) GVM in conformity with registration documents.
 2) GCM in conformity with registration documents.
 3) Axle load with standard tyre size.
 4) Chassis and cab weight calculated with: Standard specification items only with 3 litres of fuel, 0 litres of AdBlue® and driver of 90 kg, tolerance ± 3%. Changing of the specification can have major impact on vehicle weight.
 5) Other AE dimensions may be available for shown WB. Modify rear overhang to the calculated body length.
 6) CB is based on standard air intake and/or exhaust.
 7) Cab height is measured from frame member to closed cabin roof hatch.

8) Calculate customer specific body length with TOPEC. Body lengths shown based on evenly distributed load at max axle load.
 9) Unladen height at centre of driven axle(s).
 10) Laden height at centre of driven axle(s).
 11) TK = turning circle between kerbs.
 12) TW = turning circle between walls.
 13) Unladen height at centre of front axle(s).
 14) Laden height at centre of front axle(s).
 15) TB is overall width at rear. (At centre of front axle 255).

Depending on the vehicle configuration a specific option may not be possible. The availability and specification of this vehicle may differ per country. For further information please contact the DAF organisation. Pictures and technical illustrations are not binding in detail and can differ from the standard specification. Subject to modification without prior notice.